

201731 - Cremonese A-B Multi Matic 660 E15 fix HBB 431-660 HM190 argento

Disegni tecnici

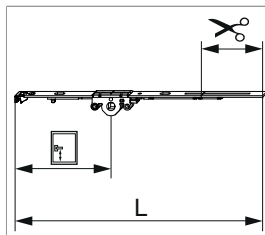

		L						Nº
argento	660	556,5	15	190	431 - 660	240,5	20	201731 ¹⁾

¹⁾ Per l'avvitamento del frontale usare il fermo per frontale (cod. 213287)

Tabella posizionamento viti

Nº		1	2	3	4	5	6	7	8	9	10	11	12	13	14
201731	2	18,5	91,5												

Tabella punti di chiusura

Nº		Z1	Z2	Z3	Z4
201731	0				

Dime

			Nº
Dima forature per fori martellina MM	per punta 3 mm	1	203861
Dima forature per fori martellina MM	per punta D=3 mm e D=12 mm	1	203862

201731 - Cremonese A-B Multi Matic 660 E15 fix HBB
431-660 HM190 argento

Quote della scatola cremonese

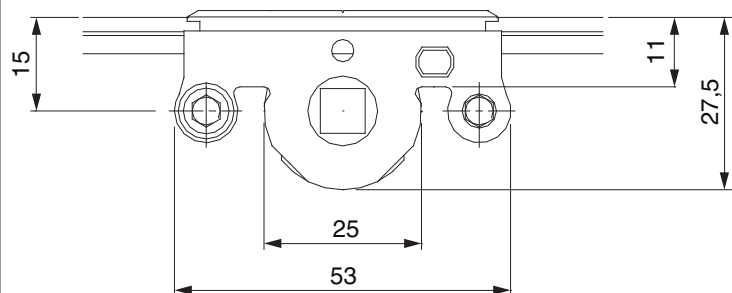

- Larghezza fresata per scatola cremonese 12 mm
- Per fissaggio maniglia utilizzare viti SPAX Ø 5 mm o viti M5.

Schema di fresata

per PVC e alluminio

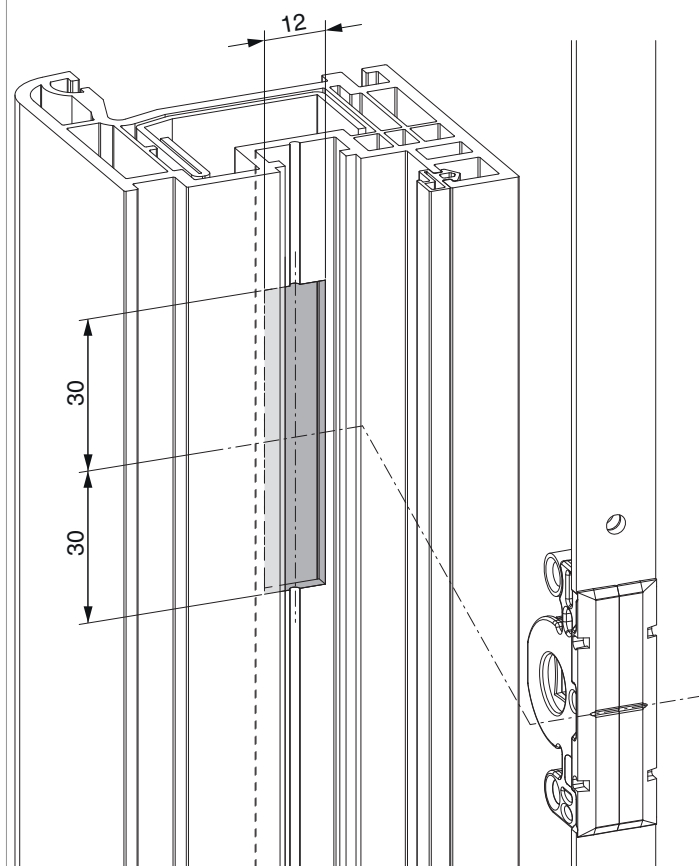

Schema di foratura

Per serramenti in legno

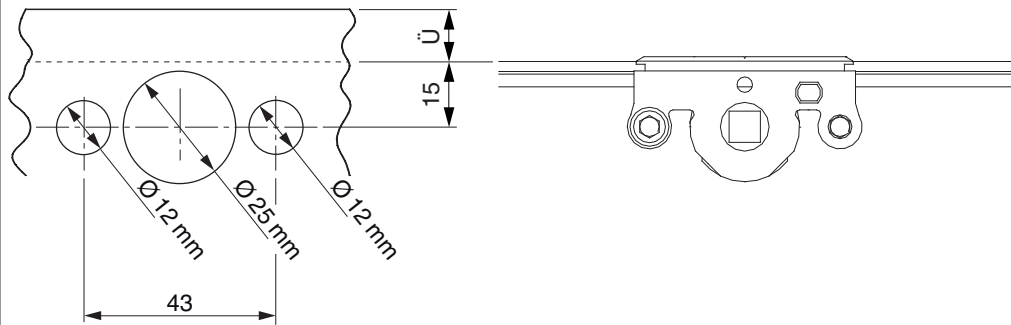

Per serramenti in PVC e alluminio

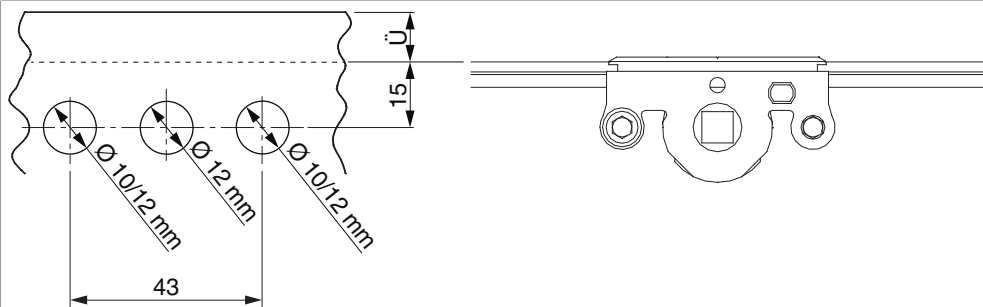

Schema di tranciatura

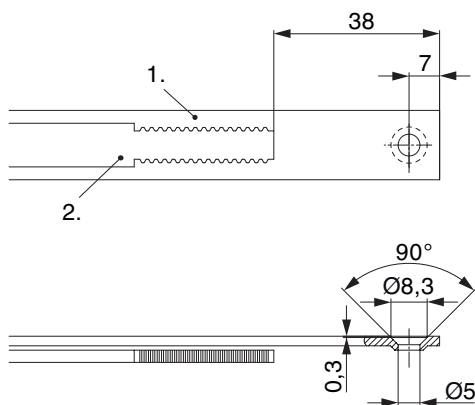

• Consigliamo di trattare il taglio dei componenti TRICOAT-PLUS con la vernice di ritocco TRICOAT-PLUS (cod. 358440).

1. Frontale
2. Asta mobile

Collegamento a clips

Agganciare collegamenta a clips

①

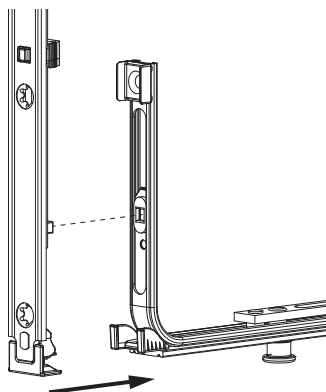

②

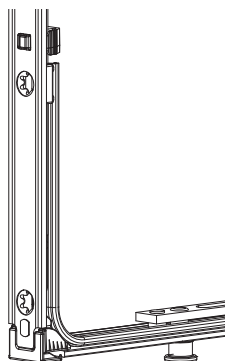

Sganciare collegamento clips

①

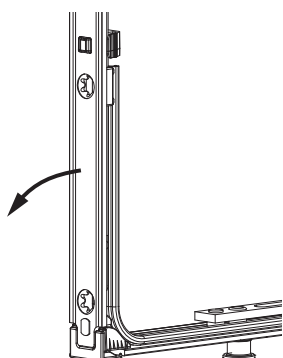

②

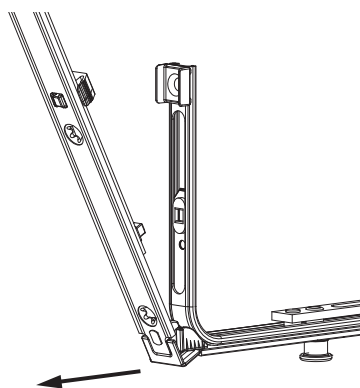

③

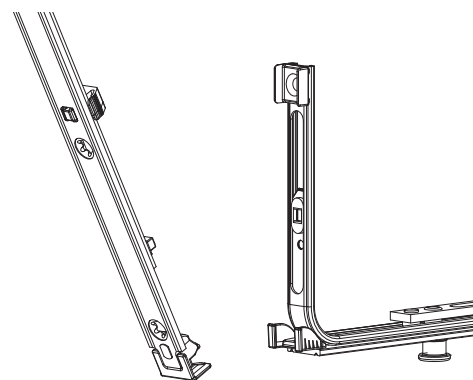

Collegamento scarpetta dentata

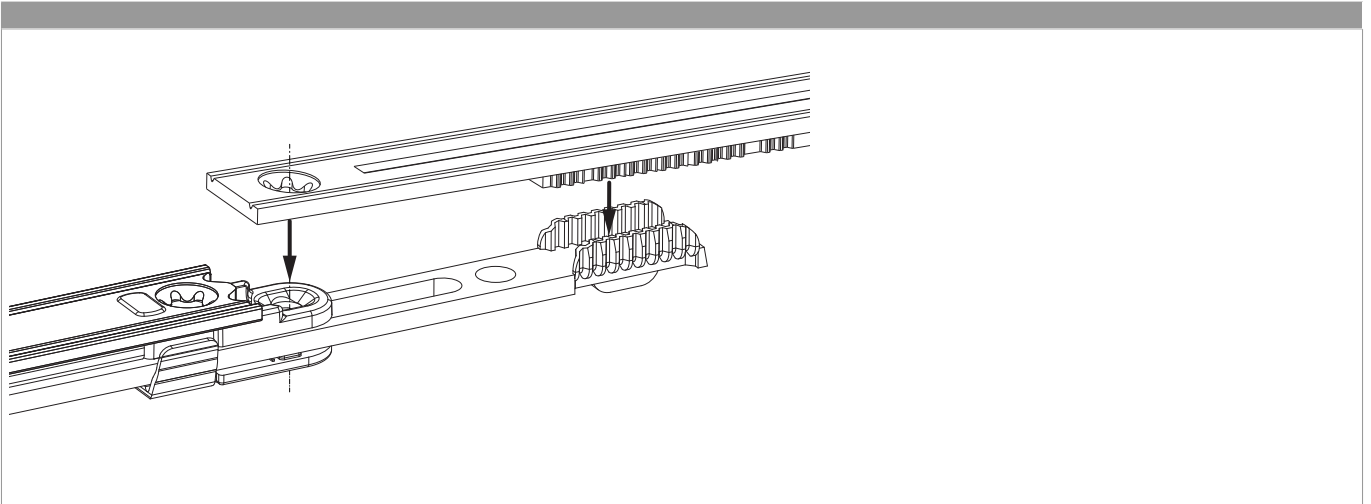

Regolazione pressione

